



Teacher Created Resources®

Skill Building For Grade 3



www.teachercreated.com

Patterned Out



Week 1: Monday

Math

Directions: Fill in the missing numbers in the blank squares. Next, read the directions below, and color in the correct squares. When you are done, you will find a mystery word colored in your chart. Write the word at the bottom of the page.

0	1						7		
10			13						
20		22		24				28	
30				34			37		
40	41								49
50			53		55				
60	61							68	
70		72				76			
80					85				89
90						96			99

- ☼ Color the squares with a seven in the ones place.
- ☼ Color the squares with a one in the ones place.
- ☼ Color the squares with a three in the ones place.
- ☼ Color the squares that have more than 6 but less than 10.
- ☼ Color the squares that have more than 40 but less than 44.
- ☼ Color the squares that have more than 46 but less than 50.
- ☼ Color the squares that have more than 96 but less than 100.
- ☼ What is the hidden word? _____



Prefixes

Week 1: Monday

Reading

Prefixes are letters added to the beginning of words to change their meanings. For example, "mis-" is the prefix of the word *misunderstood*.

Directions: Look at the meanings of the prefixes below. Then, write the meaning of each word on the line. The first two have been done for you.

☀ **dis-** = don't

☀ **pre-** = before

☀ **un-** = not

1. disobey don't obey

2. prejudge judge before

3. unhappy _____

4. disable _____

5. unlike _____

6. disagree _____

7. unbelievable _____

8. pretest _____

9. preschool _____

10. dislike _____

Writing Numbers



Week 1: Tuesday

Math

Directions: Write the numbers.

Example: one hundred sixty-nine 169

1. seven hundred seventy-eight _____

2. four hundred six _____

3. two hundred thirty-three _____

4. four hundred ninety-one _____

5. two hundred forty-seven _____

Directions: Write the following in expanded form.

Example: 868 800 + 60 + 8



6. 765 _____ + _____ + _____

7. 557 _____ + _____ + _____

8. 186 _____ + _____ + _____

9. 914 _____ + _____ + _____

10. 215 _____ + _____ + _____

Directions: Write the following using only words.

Example: 418 four hundred eighteen

11. 129 _____

12. 365 _____

13. 790 _____

14. 661 _____

15. 296 _____



Capitalization

Week 1: Tuesday

Writing

Capitalization Rule

Capitalize proper nouns, such as days, months, names, and titles of books and movies.

Directions: Circle the days, months, and titles you find in the sentences below. Then, rewrite each sentence using correct capitalization.

1. I had my birthday on a tuesday in december. _____

2. We will take a trip on a monday in june. _____

3. I saw a football game on a friday in october. _____

4. Our class went to see the music man. _____

5. We read arrow to the sun to study Native Americans. _____

6. My favorite book is harry potter and the sorcerer's stone. _____



Count the Dice



Week 1: Wednesday

Math

Directions: Count the dots on the dice. Record the number and the written form. The first one has been done for you.

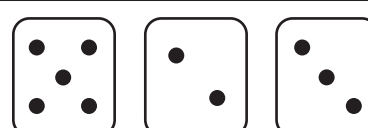
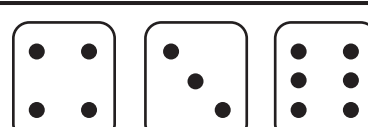
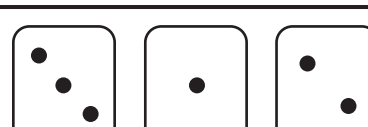
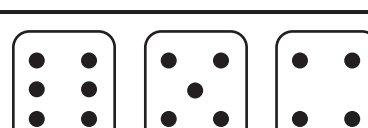
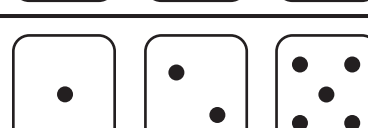
	Dice	Number	Written Form
1.		341	three hundred forty-one
2.			
3.			
4.			
5.			
6.			
7.			
8.			

What was the smallest number made? _____

What was the largest number made? _____

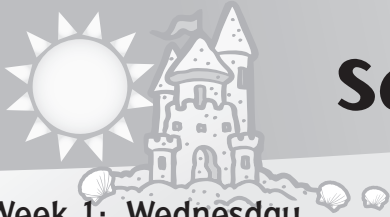

Sequencing Events

Week 1: Wednesday

Reading

Directions: Read the story. Then, write the events below in proper order.

On the night before her family vacation, Tracy began packing. She needed clothes that would keep her warm in the mountains. Tracy packed a coat and many warm sweaters. Then she packed some long pants, socks, and boots. Finally, Tracy packed some cozy pajamas. Just as she was ready to close her suitcase, she remembered her journal. She wanted to write about every detail of her vacation. As Tracy lay on her bed thinking of her exciting trip, she drifted off to sleep.

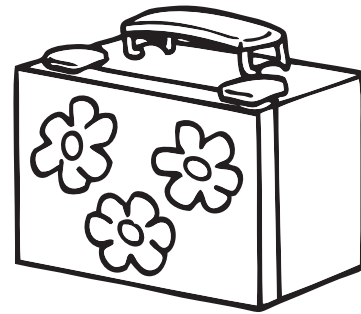

1. _____
2. _____
3. _____
4. _____
5. _____

- ⚙ Tracy packed her socks.
- ⚙ Tracy packed her journal.
- ⚙ Tracy fell asleep.
- ⚙ Tracy packed her coat.
- ⚙ Tracy packed her pajamas.

Collecting Values



Week 1: Thursday

Math

Directions: Look at the cans below. If the underlined digit is in the tens place, write the number in the tens-place barrel. If the underlined digit is in the hundreds place, write the number in the hundreds-place barrel. Place the ones in the ones-place barrel.

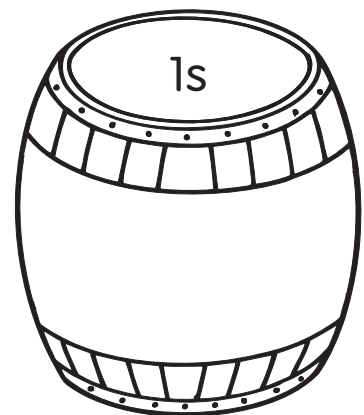
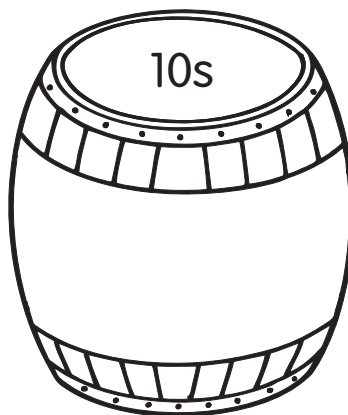
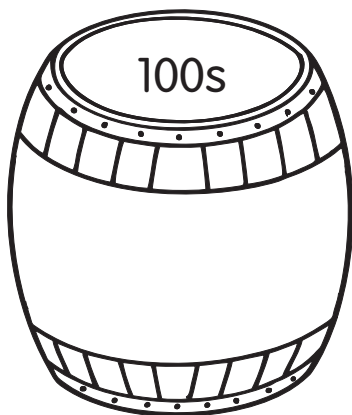



Alliteration

Week 1: Thursday

Writing

Alliteration is the use of several words close together that begin with the same consonant.

Directions: Create alliterative sentences. Replace the underlined words with words from the Word Bank. Copy each new sentence on the line below it.

Word Bank

wind	berries	bear	snake	cried
silly	poured	two	breakfast	whipped
pavement	cushion	tiny	curled up	slithered

"c" words

1. The cat sat on the pillow and meowed.

"s" words

2. One Saturday, a funny reptile moved in the dirt.

"t" words

3. A couple little turtles walked to the city.

"w" words

4. The cold breeze blew past the lake.

"p" words

5. The rain sprinkled down on the street.

"b" words

6. The animal ate food for a meal.

Solve This One



Week 1: Friday

Friday Fun

Directions: Alice wants to stack boxes into the shape of a pyramid. If she starts with eight blocks on the bottom and stacks one less block on each layer, how many blocks will she use to complete the pyramid? Draw the blocks on top of each row to complete the pattern. Write the total number in the top block.

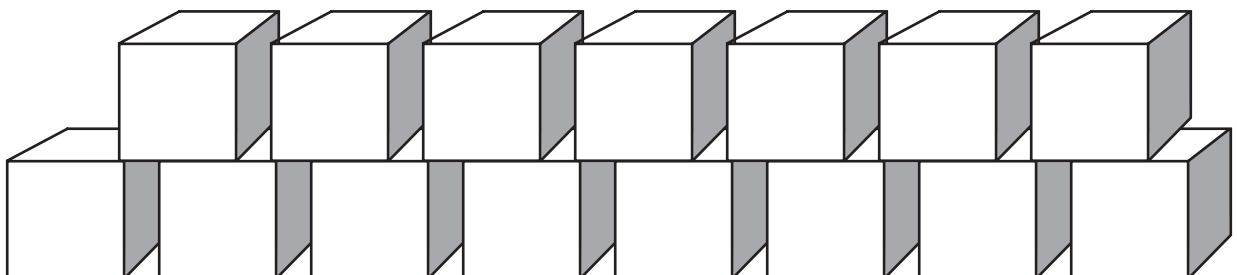



Find the Past Tense

Week 1: Friday

Friday Fun

Directions: The words below are in the present tense. Write them in the past tense on the lines, and then find them in the puzzle.



ASK _____

DRIVE _____

RECOGNIZE _____

CATCH _____

FIND _____

REPLY _____

CLAP _____

FORGET _____

SING _____

COME _____

KNOW _____

SURPRISE _____

COOK _____

LEAVE _____

THROW _____

DECIDE _____

PRETEND _____

UNDERSTAND _____

Answer Key

Page 11

Hidden word: HE

Page 12

- | | |
|----------------|--------------------|
| 3. not happy | 7. not believable |
| 4. is not able | 8. before the test |
| 5. not like | 9. before school |
| 6. don't agree | 10. don't like |

Page 13

- 778
- 406
- 233
- 491
- 247
- $700 + 60 + 5$
- $500 + 50 + 7$
- $100 + 80 + 6$
- $900 + 10 + 4$
- $200 + 10 + 5$
- one hundred twenty-nine
- three hundred sixty-five
- seven hundred ninety
- six hundred sixty-one
- two hundred ninety-six

Page 14

- I had my birthday on a **Tuesday** in **December**.
- We will take a trip on a **Monday** in **June**.
- I saw a football game on a **Friday** in **October**.
- Our class went to see The **Music Man**.
- We read Arrow to the **Sun** to study Native Americans.
- My favorite book is Harry Potter and the **Sorcerer's Stone**.

Page 15

- 254 two hundred fifty-four
- 165 one hundred sixty-five
- 523 five hundred twenty-three
- 436 four hundred thirty-six
- 312 three hundred twelve
- 654 six hundred fifty-four
- 125 one hundred twenty-five

Smallest number: 125

Largest number: 654

Page 16

- Tracy packed her coat.
- Tracy packed her socks.
- Tracy packed her pajamas.
- Tracy packed her journal.
- Tracy fell asleep.

Page 17

Ones-place barrel: 1, 3, 4, 7, 8

Tens-place barrel: 10, 37, 41, 83, 99

Hundreds-place barrel: 142, 291, 296, 429, 629

Page 18

- The cat curled up on the cushion and cried.
- One Saturday, a silly snake slithered in the dirt.
- Two tiny turtles walked to the city.
- The cold wind whipped past the lake.
- The rain poured down on the pavement.
- The bear ate berries for breakfast.

Page 19

36 blocks

Page 20

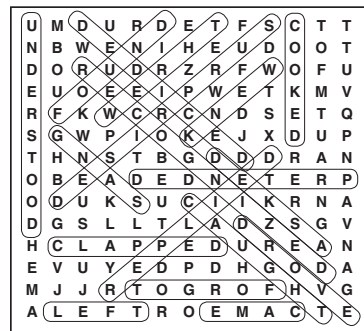

Page 21

